

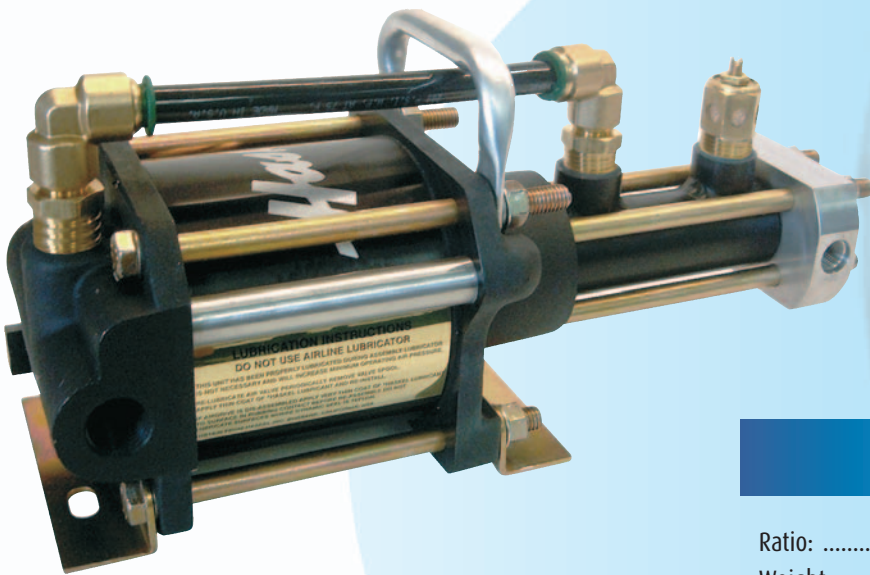

4AG-25 AIR DRIVEN GAS BOOSTER

Single Ended, Single Stage Gas Booster for Low Frequency, Low Flow Nitrogen and Oxygen Recharging



> PERFORMANCE CURVES

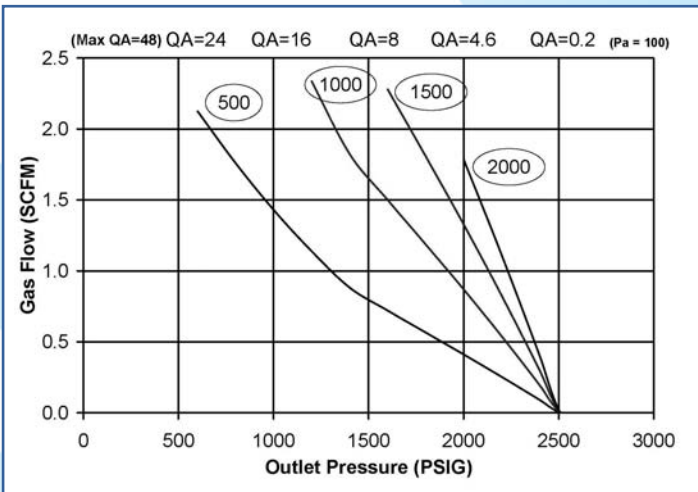

> SPECIFICATIONS

- Ratio:25:1
- Weight:12 lbs (5.44 kg)
- Volume Per Cycle:1.232 cu. in. (.0202 liter)
- Maximum Air Drive Pressure:150 psi (10.34 bar)
- Maximum Pressure Output:3,300 psi (227.53 bar)
- Minimum Gas Supply Pressure:.....100 psi (6.89 bar)

> FEATURES & BENEFITS

- Charges Gases Up To 3,300 psig (227.53 bar)
- Inlet Gas Pressures as low as 100 psig (6.89 bar)
- Lightweight Portability
- Locking Speed Control Muffler
- Relief Valve for Integrated Air Drive Protection
- Integrated Cooling Jacket and Distance Piece for extended Seal Life
- O2 cleaned option available to meet **Mil Spec 1330**



4AG-25 AIR DRIVEN GAS BOOSTER

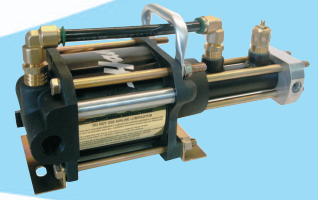

> APPLICATIONS INCLUDE

- Accumulator Gas Charging
- Gas Pressure Testing
- Charging Escape Chute/Emergency Raft
- Inflation Bottles
- Gas Spring Systems
- Hydrogen Suspension
- Charging In-flight Life Support Bottles

> MARKETS INCLUDE

- Aircraft Ground Support (Military and Commercial)
- Automotive
- Mining, Fire & Safety
- Oil & Gas
- Plastics (Gas Injection)
- Gas Manufacturing

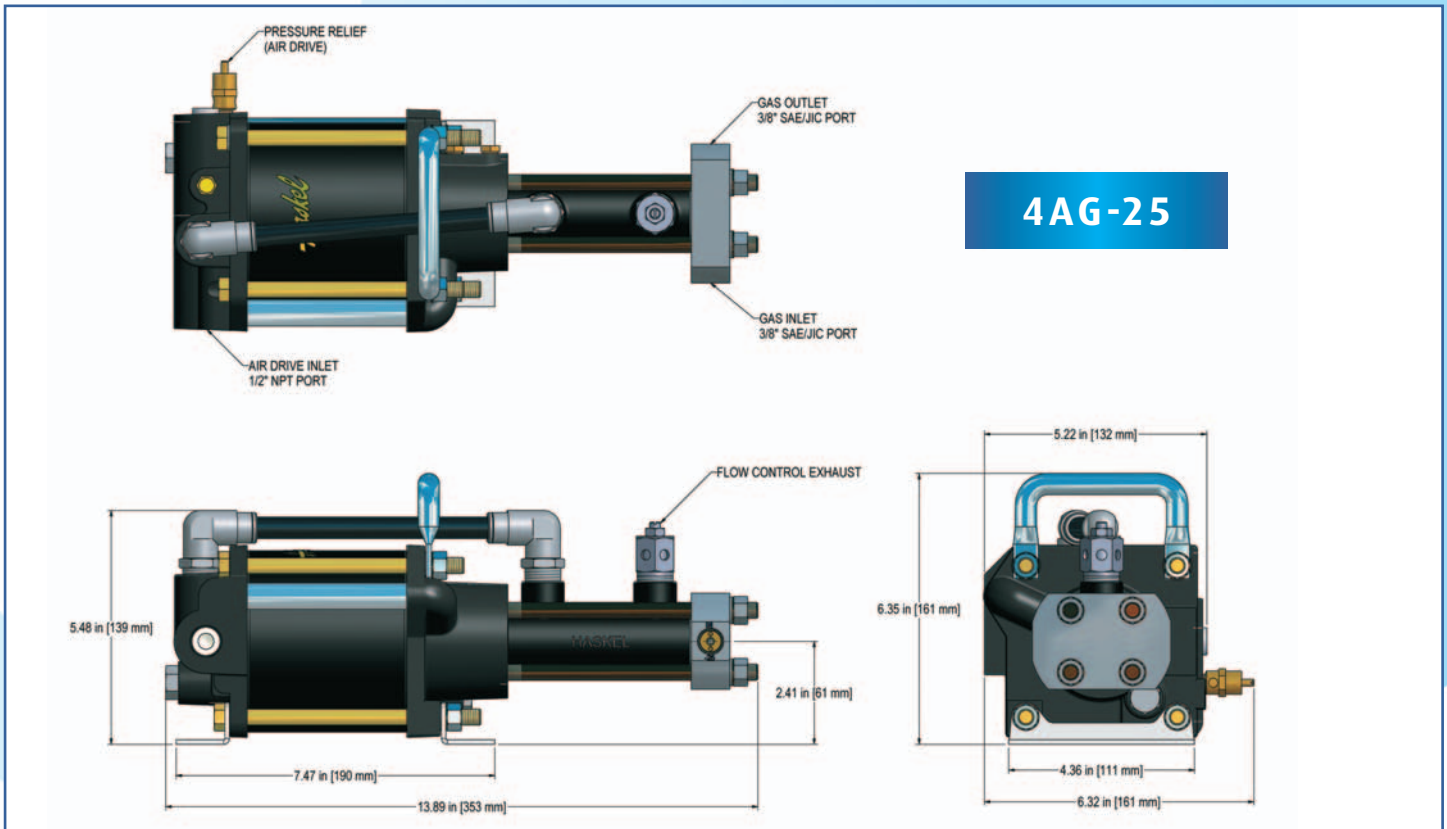

HASKEL INTERNATIONAL, INC.

100 East Graham Place,
Burbank, CA 91502 U.S.A.

PH: 818-843-4000

FAX: 818-841-4291

EMAIL: sales@haskel.com

WEB: www.haskel.com